

# 3000 LITRE POLYETHYLENE PACKAGED PUMP STATION

Effective 1st May 2003  
 Replaces all previous versions

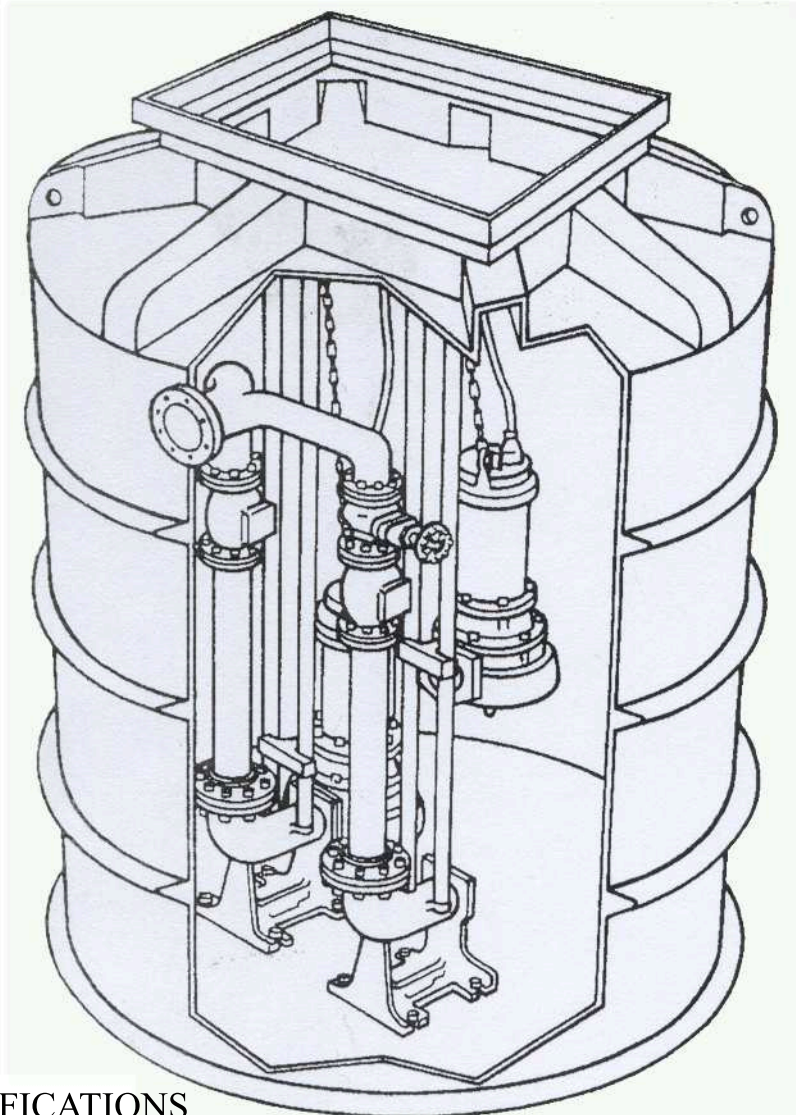

## General Arrangement

*Drawing shows dual pumps with guide rails*

### IMPORTANT NOTE:

- Intending users are reminded that:
- Written approval is required from the local sewerage authority for the installation of tanks and pumps.
  - Installation of plumbing and electrical works must be carried out by licenced contractors.
  - Tank to be filled with ballast weight before grouting concrete around sides.

## SPECIFICATIONS

Depth	Outer Diameter	Nominal Diameter	Nominal Litres	Access Cover	Approximate Weight (excluding pumps)	Standard Risers
2125mm	1730mm	1600mm	3000	900x600mm	165kg	300mm

## CONSTRUCTION

- Polyethylene Tank
- All in-tank fittings incorporated in the packaged pump station as follows:  
Bronze Gate and Non-Return Valves and Barrel Unions: PVC Interconnecting Pipework
- Inlet Pipe to be installed by plumber unless otherwise specified.

## LIQUIDS HANDLED

- Raw Sewage
- Trade Waste
- Effluent
- Stormwater

## PUMP OPTIONS

- Single Pump
  - Double Pump
- } with or without guide rails

**SEE OUR OTHER SOLUTIONS FOR : WATER MANAGEMENT**

All prices/specifications subject to change without notice.